

# IN SINK ERATOR®

## FOOD WASTE DISPOSERS

# Model 17®

The Cover Goes *In* Before the Disposer Goes *On*™

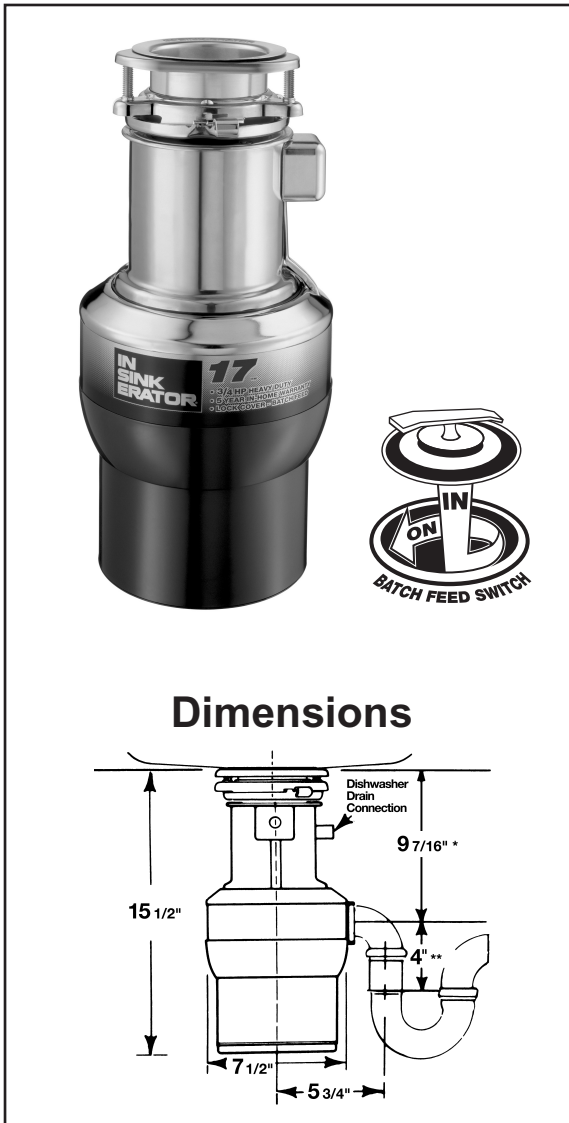

### Dimensions

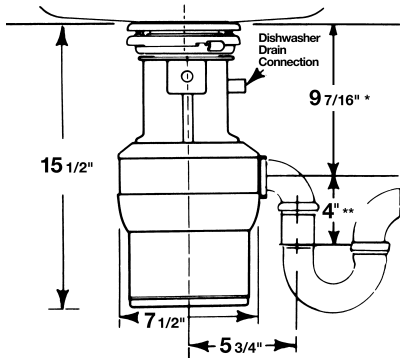

\*Distance from bottom of sink to center line of disposer outlet. Add 1/2" when stainless steel sinks are used.

\*\*Length of tailpipe from center line of disposer outlet to end of tailpipe.

NOTE: Plumb waste line to prevent standing water in disposer motor housing.

## Submittal Sheet

The Model 17 operates only when the drain cover is inserted. No wall switch is required, so installation is quick and easy.

This durable disposer also offers you these features and benefits:

- 3/4 Horsepower Heavy Duty Motor (Quiet Dura-Drive® Induction Motor)
- 5-Year *We Come To You*™ In-Home Parts And Labor Service Warranty
- Stainless Steel Grinding Components (For Increased Durability)
- Stainless Steel Grind Chamber (For Increased Reliability)

## Specifications

Type of Feed	Batch Feed
On/Off Control	Lock Cover
Motor	Single Phase
HP	3/4
Volts	120
HZ	60
RPM	1725
Amp. (Avg. Load)	7.6
Time Rating	Intermittent
Lubrication	Permanently Lubricated Upper & Lower Bearings
Shipping Weight (Approx.)	24 lbs.
Unit Finish	Grey Enamel Stainless Steel
Overall Height	15-1/2"
Grind Chamber Capacity	60 oz.
Motor Protection	Manual reset Overload
Average Water Usage	1/4 Gallon Per Person Per Day
Average Electrical Usage	1/2 KWH Per Month
Drain Connection	1-1/2" Cushioned Slip Joint
Dishwasher Drain Connection	Yes

## Sample Specification

Food Waste Disposer(s) shall be In-Sink-Erator model 17, lock cover/batch feed, with 3/4 H.P. single phase motor, corrosion protection, stainless steel grinding elements with two stainless steel 360° swivel lugs. Self-service wrench. Warranty - 5 year parts and in-home service.

\*The complete In-Sink-Erator warranty is included in the Care & Use Booklet, packed with each unit.

## Job Specifications



**EMERSON™**  
Appliance Solutions

The Emerson logo is a trademark and a service mark of Emerson Electric Co. In-Sink-Erator is a division of Emerson Electric Co.