

IN-SINK-ERATOR®

INSTANT HOT WATER DISPENSERS

Model H-990 Instant Hot Water Dispenser

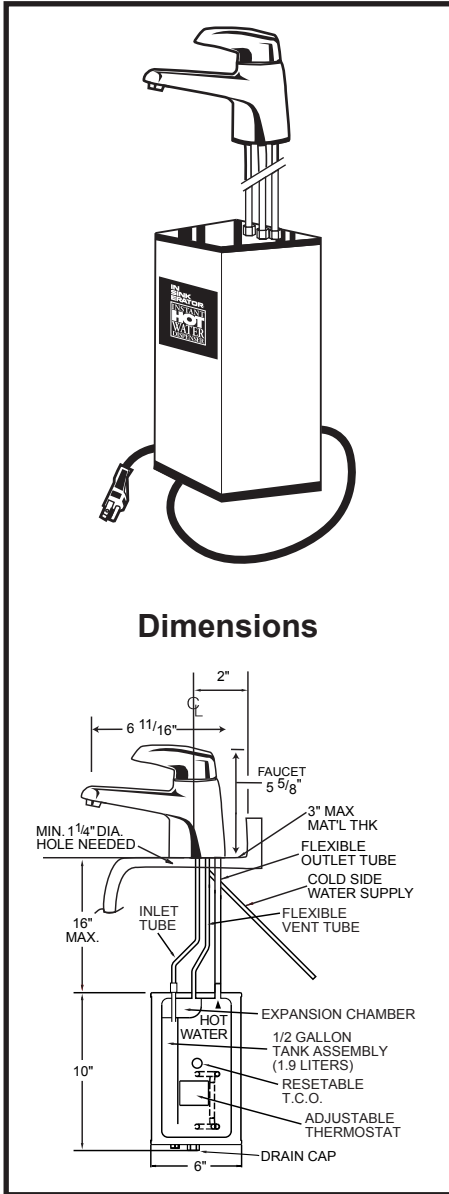

Dimensions

Submittal Sheet

This model offers you these features & benefits:

- 1 Year "We Come To You"™ In-Home Parts and Labor Warranty
- Contemporary European styled faucet
- Manually resettable thermal overload protector
- Available in Chrome, White & Sand

The complete In-Sink-Erator warranty is included in the Care & Use Booklet, packed with each unit.

Sample Specification

- Capacity – ½ gallon tank dispenses 60 cups of 190°F water per hour
- Electrical – 115 volts A.C., 750 watts, 6.5 amp heating element with grounded three (3) prong plug
- Thermostat – Snap action, adjustable from 140°F to 200°F (factory pre-set at approximately 190°F)
- Insulation – Meets U.L. 94HF-1 flammability specification
- Hot Valve – Instant self-closing
- Shipping Weight – Approximately 8 lbs.
- To ensure optimum performance, maximum distance between tank and dispenser head should be 16" or less

Specifications

Capacity	½ gallon tank dispenses 60 cups of 190°F water per hour
Electrical	115 volts A.C, 750 watts, 6.5 amp heating element with grounded three (3) prong plug
Thermostat	Snap-action, adjustable from 140°F to 200°F (factory pre-set at 190°F)
Insulation	Meets U.L. 94HF-1 flammability specification
Hot Valve	Instant, self-closing
Shipping Weight	Approximately 8 lbs.
Required Hole Diameter	1¼" - 1½"



Job Specifications



The Emerson logo is a trademark and a service mark of Emerson Electric Co. In-Sink-Erator is a division of Emerson Electric Co.