

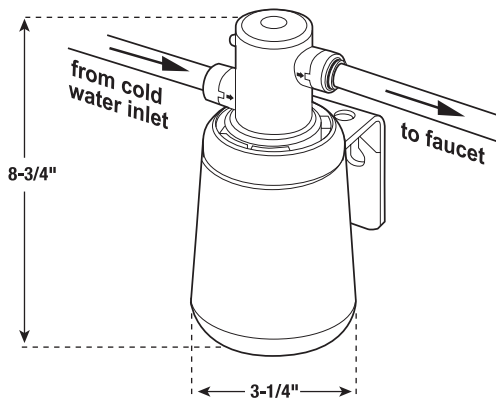

The Next Necessity™



Dimensions



Job Specifications

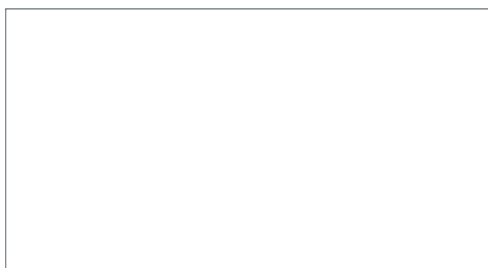

Instant Hot Water Dispensers

Model F-201 Filtration System

The only filtration system designed exclusively For instant hot water dispensers

Submittal Sheet

- Ideal for any instant hot water dispenser, refrigerator, icemaker, or virtually any drinking water system
- Reduces Chlorine, taste and odor for clean, refreshing taste
- Quick-connect fittings guarantee easy installation
- Sanitary, quick-change filter cartridge makes replacement easy. A simple twist is all it takes!
- Automatically shuts off water when filter cartridge is replaced
- 6-12 month recommended filter cartridge replacement

Warranty:

1-year parts and in-home service* (excluding replaceable filter cartridge)

* The complete InSinkErator warranty is included in the Care & Use booklet packed with each unit.

F-201R Cartridge (included with this system) Chemical & Mechanical Reduction Filter Specifications:

This cartridge provides mechanical and chemical reduction of dirt/rust, chlorine taste and odor, and particulates.



System Tested and Certified by NSF International against NSF/ANSI Standard 42 for the reduction of Chlorine taste and odor and Nominal Particulate Class I.

Pressure: 30-125 psi
Temperature: 33°F - 100°F
Flow Rate: 0.75 gpm
Capacity: 500 gallons

Filter Capacity: 500 gallons, depending on local water conditions. Note that while the testing was performed under standard laboratory conditions, actual performance may vary. Do not use with water that is microbiologically unsafe or of unknown quality without adequate disinfection before or after the system. For cold water use only. Systems must be installed and operated in accordance with the Manufacturer's recommended procedures and guidelines. See warranty card for warranty. For service and parts, contact your local dealer or InSinkErator® directly at 1-800-558-5700.

Contaminant Reduction	Average Influent ppm	Influent Challenge Concentration, Except As Noted, Units Apply to Each Row.	Avg. Product Water ppm	Average % Reduction	NSF Red. Requirements	NSF Test
Chlorine, Taste and Odor	2.1	2.0 mg/L ± 10%	0.07	96.6	> 50%	516345-05
Nominal Particulate Class I Particle Size = 0.5 to 1 um	12666667	At least 10,000 particles/ml	790666	93.7	> 85%	J-00025192

Application guidelines/Water Supply Parameters for NSF Testing: Service flow of 0.75 gpm, community or private well water supply, water pressure of 20-120 psi, water temperature of 33°F-100°F. Except as noted, all testing performed at pH = 7.5 ± 0.5, Flow: 0.75 gpm, Pressure: 60 psi, Temp: 20° ± 3°C.

Contact an authorized InSinkErator service agent for repairs or replacement components.



EMERSON™
Appliance Solutions

The Emerson logo is a trademark and service mark of Emerson Electric Co.

InSinkErator may make improvements and/or changes in the specifications at any time, in its sole discretion, without notice or obligation and further reserves the right of change or discontinue models.

© 2011 InSinkErator, a division of Emerson Electric Co. All Rights Reserved.